



SECTION 0 - GENERAL

0.0 Flight Manual Approval

Kavanagh Balloons Approved Hot Air Balloon Flight Manual

Models:

B-77, B-105, B-350, B-400

C-56, C-65, C-77

D-77, D-84, D-90, D-105

E-120, E-140, E-160, E-180, E-210, E-240, E-260, E-300

EX-65

G-450

THIS PAGE INTENTIONALLY BLANK

Applicable to Serial Numbers as shown in Section 1.2

This manual is specific to the following balloon

Model _____

Serial Number _____

Construction Date _____

Registration Mark _____

Approved By _____

For the Civil Aviation Safety Authority Australia

Approval Date _____



2 Sep 2010

This page CASA approved



THIS PAGE INTENTIONALLY BLANK



0.1 Log of Revisions

Revision Number	Revised Pages	Approval Date	Approval Signature
1	0-1, 0-3, 0-7, 3-3, 4-17	2nd Sep 2010	

This page CASA approved



THIS PAGE INTENTIONALLY BLANK



0.3 Log of Effective Pages

Page	Revision	Page	Revision	Page	Revision
0-1	1	3-7	0	7-3	0
0-2	Blank	3-8	Blank	7-4	0
0-3	1	4-1	0	7-5	0
0-4	Blank	4-2	0	7-6	0
0-5	0	4-3	0	7-7	0
0-6	Blank	4-4	0	7-8	0
0-7	1	4-5	0	7-9	0
0-8	Blank	4-6	0	7-10	0
0-9	0	4-7	0	7-11	0
0-10	Blank	4-8	0	7-12	0
0-11	0	4-9	0	7-13	0
0-12	0	4-10	0	7-14	0
0-13	0	4-11	0	7-15	0
0-14	0	4-12	0	7-16	0
0-15	0	4-13	0	7-17	0
0-16	Blank	4-14	0	7-18	0
1-1	0	4-15	0	7-19	0
1-2	0	4-16	0	7-20	0
1-3	0	4-17	1	7-21	0
1-4	0	4-18	0	7-22	0
2-1	0	4-19	0	8-1	0
2-2	0	4-20	0	8-2	0
2-3	0	4-21	0	8-3	0
2-4	0	4-22	0	8-4	0
2-5	0	4-23	0	8-5	0
2-6	0	4-24	Blank	8-6	0
2-7	0	5-1	0	9-1	0
2-8	Blank	5-2	0	9-2	Blank
3-1	0	5-3	0		
3-2	0	5-4	Blank		
3-3	1	6-1	0		
3-4	0	6-2	0		
3-5	0	7-1	0		
3-6	0	7-2	0		

APPROVED:  DATE: 2 Sep 2010
For Civil Aviation Safety Authority

This page CASA approved



THIS PAGE INTENTIONALLY BLANK



0.5 Table of Contents

SECTION 0 - GENERAL	0-1
0.0 Flight Manual Approval	0-1
0.1 Log of Revisions	0-3
0.2 General Amendment Record	0-5
0.3 Log of Effective Pages	0-7
0.4 List of Supplements	0-9
0.5 Table of Contents	0-11
SECTION 1 - GENERAL INFORMATION	1-1
1.1 Introduction	1-1
1.2 Certification Basis	1-2
1.3 Definitions	1-3
1.4 Abbreviations	1-4
SECTION 2 - LIMITATIONS	2-1
2.1 Gross Certificated Weight	2-1
2.2 Envelope Temperature	2-2
2.3 Rate of Climb	2-2
2.4 Meteorological conditions	2-2
2.5 Altitude	2-2
2.6 Minimum Burner Requirements	2-3
2.7 Fuel	2-3
2.8 Baskets	2-4
2.9 Number of Occupants	2-4
2.10 Flight Crew	2-4
2.11 Smoking	2-5
2.12 Mandatory Equipment	2-5

This page CASA approved



THIS PAGE INTENTIONALLY BLANK



4.9	Pre-Launch Checks	4-9
4.10	Launch	4-10
4.11	Flight	4-11
4.11.1	In-flight Venting - Parachute Operation	4-11
4.11.2	In-flight Venting - Circular Velcro Rip Panel	4-12
4.11.3	Lite Vent Closing Line	4-13
4.11.4	Rotation Vents	4-13
4.11.5	Burner Operation - Main Burner	4-14
4.11.6	Burner Operation - Liquid Fire	4-14
4.11.7	Fuel Management	4-15
4.11.8	Fuel Tank Hose Change	4-15
4.11.9	Use of Fuel Tank Manifolds	4-16
4.11.10	Pilot Restraint Harness	4-16
4.12	Approach to landing	4-17
4.13	Intermediate Landing	4-18
4.13.1	Intermediate Landing - Parachute Vent.	4-18
4.13.2	Intermediate Landing - Smart & Lite Vent	4-18
4.13.3	Intermediate Landing - Rip Panel	4-19
4.14	Final Landing	4-19
4.14.1	Final Landing - Parachute Vent	4-19
4.14.2	Final Landing - Smart & Lite Vent	4-20
4.14.3	Final landing - Circular Velcro Rip Panel	4-21
4.15	Install the Circular Velcro Rip Panel	4-22
SECTION 5 - PERFORMANCE		5-1
5.1	Calculation of Payload	5-1
5.2	Lift Chart	5-2
5.3	Loading System	5-3
SECTION 6 - WEIGHTS		6-1
6.1	Weights	6-1
6.2	Fuel Tank Weights	6-2

**SECTION 7 - SYSTEM DESCRIPTION****7-1**

7.1	Introduction	7-1
7.2	Envelope	7-1
7.2.1	Type B Balloons	7-2
7.2.2	Type C Balloons	7-2
7.2.3	Type D Balloons	7-2
7.2.4	Type E Balloons	7-2
7.2.5	Type EX Balloons	7-2
7.2.6	Type G Balloons	7-3
7.2.7	Parachute Vent	7-3
7.2.8	Smart Vent	7-4
7.2.9	Lite Vent	7-5
7.2.10	Circular Velcro Rip Panel	7-7
7.2.11	Rotation Vents	7-8
7.2.12	Scoop Skirt	7-9
7.3	Basket	7-9
7.4	Launch Restraints	7-11
7.5	Burner System	7-12
7.5.1	Main Burner	7-12
7.5.2	Liquid Fire	7-12
7.5.3	Pilot Lights	7-13
7.5.4	Cross Flow Valve	7-14
7.5.5	Pressure Gauge	7-14
7.6	Fuel Tanks	7-14
7.6.1	Fuel Tank Capacity	7-15
7.6.2	Contents Gauge	7-15
7.7	Mini Vapour Tanks	7-16
7.8	Fuel Manifolds	7-16
7.9	Fuel	7-16
7.10	Instrumentation	7-16
7.10.1	Ball 655/M55	7-17
7.10.2	Ball 659	7-17
7.10.3	Flytec 4005/4010/3040/6005/6010	7-17

This page CASA approved



7.10.4	Brauniger AV & IQ Classic/Competition	7-17
7.10.5	Aircotec Piccolo Plus/ACT5000	7-18
7.11	Radio Systems	7-18
7.12	Equipment Lists	7-18
7.12.1	Envelope list	7-19
7.12.2	Basket List	7-20
7.12.3	Load Frame List	7-21
7.12.4	Burner List	7-21
7.12.5	Fuel Tank List	7-22

SECTION 8 – SERVICING**8-1**

8.1	Servicing Introduction	8-1
8.2	Nature of Propane	8-1
8.3	Refuelling	8-2
8.3.1	Filling Tanks not fitted with Fill Limiters	8-2
8.3.2	Filling Tanks fitted with Fill Limiters (AFL)	8-3
8.4	Water Contamination	8-4
8.5	Fuel Tank Pressurization	8-4
8.5.1	Storage of Pressurized Tanks	8-5
8.5.2	Refuelling Pressurized Fuel Tanks	8-6
8.5.3	Returning to use as a Master Tank	8-6

SECTION 9 - SUPPLEMENTS**9-1**

This page CASA approved



1.4 Abbreviations

AFL	Automatic Fill Limiter
AGL	Above Ground Level.
AMSL	Above Mean Sea Level.
CASA	Civil Aviation Safety Authority.
CASR	Civil Aviation Safety Regulation
Cu.Ft	Cubic Feet
Cu.M	Cubic Metres
FLLG	Fixed Liquid Level Gauge.
FPM	Feet Per Minute.
GCW	Gross Certificated Weight.
I.S.A.	International Standard Atmosphere
KG	Kilograms
KPA	Kilopascals
LPG	Liquefied Petroleum Gas.
PSI	Pounds Per Square Inch
VHF	Very High Frequency
UHF	Ultra High Frequency



SECTION 1 - GENERAL INFORMATION

1.1 Introduction

This Flight Manual has been prepared to provide pilots with information for the safe operation of all Kavanagh hot air balloons.

In particular, this manual applies to the balloon identified by model, registration marking and serial number on Page 0-1 and this model designation is used to identify the airworthiness limitations and essential data for the balloon contained in this manual.

Special operations requiring additional limitations and instructions are listed in "Section 9 - Supplements" and this section shall be consulted before undertaking any such operations. For operating information not included in this Manual, reference should be made to the appropriate Operations or Manufacturers' Manuals.

The Flight Manual shall be carried in the balloon on all flights. It is the responsibility of the pilot in command to be familiar with the contents of this Manual and to comply with all directions contained herein relating to the operation of the balloon.

Amendments and revisions to this Manual will be issued when necessary and will be available for download from the Kavanagh Balloons website.

www.kavanaghballoons.com.au

Notification of amendments can be received via email by subscribing to the technical documents mailing list on the above website.



1.2 Certification Basis

The types of balloon to which this manual is applicable have been approved by the Civil Aviation Safety Authority of Australia, in accordance with CASR Part 31, under the following Type Certificates and Certificates of Type Approval:

VL507 Kavanagh Type B, C, D, E, EX & G. From Serial No: 361

TC's (prefix VL), listed below apply to all Serial Nos. lower than those listed next to each TC:

VL501	Kavanagh Type B	372
VL502	Kavanagh type EX	342
VL503	Kavanagh Type G	344
VL504	Kavanagh Type E	371
VL505	Kavanagh Type C	336
VL506	Kavanagh Type D	376

Certificate of Type Approval, CTA 148-2

This manual applies only to the serial numbers listed below:

207, 213, 215, 231,
284, 285, 288, 290
295, 297, 301, 306,
311, 312.

Each model has been certificated on the basis of the equipment fitted at the time of certification. Any changes in equipment are subject to approval by the Civil Aviation Safety Authority.

No entries or endorsements may be made in this Flight Manual except in the manner, and by persons, authorised for the purpose by the Civil Aviation Safety Authority of Australia.



1.3 Definitions

The following definitions shall apply throughout this Manual:

WARNING: *Operating procedures, techniques, etc., which could result in personal injury or loss of life if not carefully followed.*

CAUTION: *Operating procedures, techniques, etc., which could result in damage to equipment if not carefully followed.*

NOTE: *An operating procedure, technique etc., which is considered essential to emphasize.*

AIRFIELD PRESSURE HEIGHT

The Airfield Pressure Height is that height registered at the surface of an aerodrome by an altimeter with the pressure sub-scale to 1013.2 hectopascals (millibars).

GROSS CERTIFICATED WEIGHT (GCW)

The maximum permissible total weight of the balloon and all its equipment at take off including fuel, instruments, passengers and crew.

APPROVED

Pertaining to materials or aircraft parts; this includes all parts and materials which are approved by Kavanagh Balloons and/or CASA.



2.8 Baskets

1. A minimum of one hand hold is required per passenger.
2. Adequate space for passengers to assume a safe landing position is required in all passenger compartments.
3. Where the basket exceeds the length to width ratio of 1.4:1, rotation vents must be fitted to the envelope.
4. Where cushioned flooring is fitted to a basket, all drain holes must remain clear.

2.9 Number of Occupants

1. The maximum number of occupants is set by the number of available compartments in the basket.
2. Open baskets are limited to 7 occupants, including flight crew.
3. Partitioned baskets are limited to a maximum of 6 people per passenger compartment and 2 flight crew in the pilot compartment.
4. All occupants must have reasonable space to achieve a safe landing position and reasonable comfort levels during the flight.
5. All occupants must have access to a minimum of one hand hold eg: rope handle or tank rim.
6. The pilot must have adequate space to access and operate all fuel systems and control lines.

2.10 Flight Crew

1. Minimum flight crew is one person, however there must be sufficient weight on board so the balloon can be flown in a controlled manner. See Section 2.1 for minimum landing weight.



SECTION 2 - LIMITATIONS

2.1 Gross Certificated Weight

Table 1 - Volume and GCW for each model

Model	Volume		CGW(KG)
	Ft ³	m ³	
B-77	77,500	2195	760
B-105	105,500	2973	1030
B-350	350,000	9911	2800
B-400	400,000	11327	3100
C-56	56,000	1586	550
C-65	65,000	1841	635
C-77	77,500	2195	760
D-77	77,500	2195	760
D-84	84,000	2379	824
D-90	90,000	2549	902
D-105	105,500	2973	1030
E-120	120,000	3398	1175
E-140	140,000	3964	1300
E-160	160,000	4531	1400
E-180	180,000	5097	1450
E-210	210,000	5947	1900
E-240	240,000	6796	2000
E-260	260,000	7362	2200
E-300	300,000	8495	2500
EX-65	65,000	1841	638
G-450	450,000	12743	3700

1. The above table shows the volume and maximum permissible operating weight for each model balloon without regard to ambient conditions.



- The maximum operating weight for any intended flight must be determined from the performance section, (Section 5).
- The minimum landing weight for any model greater than 140,000cu.ft must not be less than 50% of the gross certificated weight.

2.2 Envelope Temperature

- For all models the maximum envelope temperature is 120 degrees Celsius.

2.3 Rate of Climb

- With the exception of the "EX" type balloons, the maximum allowable rate of climb is 1000fpm.
- For "EX" type balloons, the maximum allowable rate of climb is 1600fpm.

WARNING: If there is any damage to the envelope within the acceptable limits shown in 2.11 (1) of this section, the maximum rate of climb must be reduced to 50% of the maximum allowable rate of climb for that model.

2.4 Meteorological conditions

- The balloon must not be launched in winds exceeding 15 knots at ground level.
- Flights must not be conducted if there is extensive convective activity in the area such as thunderstorms and thermals.

2.5 Altitude

- Maximum permissible operating altitude is that height above ground level at which the burner fails to maintain ignition or that height, at which the maximum temperature is reached, whichever happens first.



- For flights above 10,000ft, flight crew and passenger oxygen must be used in accordance with Civil Aviation Regulations.

2.6 Minimum Burner Requirements

- The following table sets out the minimum burner requirements based on envelope volume using a Kavanagh Series 3 burner in one of four configurations.

Table 2 - Minimum burner requirements

Balloon Volume	Burner Configuration
56 - 90 (1586 - 2549 cu.m)	Single (KBS3-1)
105 - 210 (2973 - 5947 cu.m)	Double (KBS3-2)
240 - 350 (6796 - 9911 cu.m)	Triple (KBS3-3)
400 - 450 (11327 - 12743 cu.m)	Quad (KBS3-4)

2.7 Fuel

- Fuel for the burner is LPG. Propane is the preferred fuel but some content of other hydrocarbons is permissible provided that at least the minimum fuel pressure is maintained.
- The normal operating range of the burner is 350 - 1500KPA (50 - 218PSI)
- A minimum of two fuel tanks must be carried at all times in balloons fitted with single or double burners. For balloons fitted with triple burners, three tanks must be carried and four tanks if a quad burner is fitted. Additional fuel tanks may be carried.
- There must be one tank fitted for supply of regulated vapour for each vapour supply hose fitted to the burner.
- All fuel tanks must be secured by two approved tank straps.
- All fuel tanks used must have a padded jacket with water resistant outer and not less than 19mm thick foam.



THIS PAGE INTENTIONALLY BLANK



2.11 Smoking

1. Smoking is not allowed while the balloon is being prepared for, or during flight.
2. A placard bearing the statement "NO SMOKING" must be displayed on the inside of the basket or on fuel tanks or on the load frame or on the underside of a heat shield.

2.12 Mandatory Equipment

The following equipment is the minimum that must be carried each time the balloon is flown. Civil Aviation Regulations may require other equipment additional to this list.

1. Fire extinguisher, minimum of 1kg, dry powder (ABE).
2. Altimeter, with operational range suitable for the flight.
3. Vertical speed indicator, (Variometer).
4. Envelope temperature indication. Either constant reading or warning signal such as a fusible link.
5. Ambient temperature indicator.
6. Handling line, not less than 25m in length.
7. Aircraft flight manual.
8. Matches or a hand held igniter must be carried in the basket as a secondary means of pilot or main burner ignition.



2.13 Allowable Damage

The following unservicabilities are allowed provided repairs are carried out at the first available opportunity.

Where damage outside of these limits is found, the limits in the Maintenance Manual shall be applied.

1. Use of a scoop is optional. The balloon may be flown without a scoop or with unlimited damaged to the scoop.
2. Fabric damage including burns, holes or tears are permitted as per Table 3.

Table 3 - Allowable fabric damage.

Size	Location	Max. per Panel	Total
Less than 5mm	All	3	20
5-10mm	All	1	3
10-50mm	Below the 3rd horizontal load tape.	1	3
50-500mm	Panel 4 or lower	1	3
500-1000mm	Panels 1 & 2	1	2

NOTE: *Where more than one size of damage occurs on the same panel, the total per panel must not exceed 3 items within their individual panel limits.*

Where multiple holes are located in the same panel, the damage must be separated by more than 20mm or it is considered one area of damage and measured accordingly.

3. On burners with two or more peizo ignition systems (double, triple and quad burners), one peizo igniter may be unservicable.



2.14 Parachute Vent

1. Operation of the parachute vent in flight is permissible until distortion of the balloon is apparent. Once distortion is apparent, the vent must be closed and the balloon allowed to re-inflate.
2. If the distortion persists, the balloon should be stabilised by using the burner in short bursts until the vertical speed decreases and the balloon is again fully inflated.

2.15 Smart Vent & Lite Vent

1. Operation of the parachute mode in flight is permissible until distortion of the balloon is apparent. Once distortion is apparent, the vent must be closed and the balloon allowed to re-inflate.
2. If the distortion persists, the balloon should be stabilised by using the burner in short bursts until the vertical speed decreases and the balloon is again fully inflated.
3. The centre pull rip line must not be activated if the basket floor is more than 2 metres (six feet) above ground level unless during an emergency landing.

WARNING: *Operation of the Lite Vent or Smart Vent centre pull rip line will cause the balloon to empty very quickly and could cause damage and/or injuries if this limitation is ignored.*

2.16 Circular Velcro Rip Panel

1. The Circular Velcro Rip Panel must not be opened if the basket floor is more than 2 metres (six feet) above ground level except in an emergency landing.

WARNING: *Operation of the Circular Velcro Rip Panel cannot be reversed so care must be taken to ensure the final landing is imminent before deploying the rip panel. Premature opening could cause damage and/or injuries if this limitation is ignored.*



fuel spraying from relief valves and a possibility of explosion from overheated fuel tanks.

4. If the balloon is inflated, the deflation system must be activated to prevent the balloon from climbing as crew and passengers exit the basket.

3.6 Fire in Flight

1. Turn off fuel at main tank valves and turn off pilot burners.
2. Put out the fire with the fire extinguisher.
3. If it is safe, relight pilot burner, proceed as normal and make a landing as soon as possible.
4. If it is unsafe to relight the burner, prepare to make an emergency/hard landing.

3.7 Envelope Over Temperature Indication

1. If an envelope over temperature is indicated - either by a continuous temperature indicator or warning signal such as a fusible link, descend to the minimum safe altitude.
2. If a continuous reading temperature gauge is available, the flight may be continued provided the envelope temperature is within limits.
3. If there is no further over temperature indicator available, a landing must be made as soon as possible.

3.8 Pilot Burner Failure

In the event of pilot burner failure, adopt the following course of action:

1. If multiple burners are fitted, continue the flight on another burner while troubleshooting the pilot burner failure.
2. Check the pilot burner valve has not been inadvertently turned off at the burner.



SECTION 3 - EMERGENCY PROCEDURES

3.1 Introduction

This section provides procedures for emergency situations that may occur in flight or on the ground.

3.2 Avoidance of Low Level Objects

If a collision with an object on the ground appears possible, the pilot must quickly make the decision whether it is better to climb or descend.

NOTE: *From stable flight the balloon responds faster when a descent is initiated than when action is taken to begin a climb.*

3.2.1 Emergency Climb

1. The situation must be assessed quickly, and if the decision to climb is made it must be made only if the pilot is certain that the obstacle can be cleared.
2. Activate as many available burners, including liquid fire as required, to initiate the climb.

3.2.2 Emergency Descent

1. If the decision to descend is made, brief the crew and passengers and carry out an emergency landing using the parachute mode of the vent to increase the rate of descent if necessary.
2. Prepare for a hard landing as described in 3.4



3.3 Accidental Operation of the Rip Line

Accidental operation of the rip line in a Smart Vent or Lite Vent will be noticed by a different feel in the load on the control line as the vent starts to open.

In a balloon fitted with a Circular Velcro Rip Panel, the rip locks will provide a positive indication that the rip panel is being opened.

1. Release the rip line immediately.

CAUTION: Unless the final deflation system is a Parachute Vent, the vent will not close automatically.

2. For Smart Vent and Lite Vent, close the vent by use of the parachute line.
3. For Circular Velcro Rip Panels, assess the amount the panel has been opened. There is no way to re-close the panel from the basket.
4. Turn the burner(s) on to replace any lost lift and bring the balloon under control.
5. If it is obvious that control can not be regained before contact with the ground, prepare for a heavy landing.

3.3 Power Line Contact

If contact with power lines is unavoidable follow the following procedures.

1. Descend as fast as possible so that the contact is made with the envelope and not with the basket assembly.
2. Take care to ensure no one is holding any metallic parts of the basket, fuel tanks or burner.
3. If there is no risk of fire, remain in the basket until the power company is contacted and it has been confirmed that the power has been turned off.



4. If the basket must be evacuated, crew and passengers must avoid contact between their bodies and any part of the balloon at the same time.

3.4 Hard Landing Procedures

Hard landings may result from emergency manoeuvres or pilot error. The following procedures will reduce the risk to crew and passengers during a hard landing.

1. Crew and passengers must be briefed for the hard landing - holding onto rope handles or fuel tank rims, feet together and knees slightly bent. In partitioned baskets, passengers should have their back to the direction of landing with their back or hip firmly against the padded wall.

When a high horizontal landing speed is expected, passengers should be made aware that the basket will tip forward and they should take a lower than normal landing position to avoid being thrown forwards out of the basket.

2. Pilot lights and the main burner **must** be extinguished prior to contact with the ground.
3. If time permits, fuel should be shut down at the fuel tanks and fuel in the lines vented/burnt.
4. Emergency ballast such as surplus fuel tanks may be jettisoned provided there is no risk to people on the ground.
5. The rip line should be fully operated and held open just before contact to reduce rebound or drag if either is likely.

3.5 Fire on the Ground

1. Turn off fuel at the main tank valves.
2. Use the fire extinguisher to put out fire.
3. If this action proves unsuccessful after 30 seconds or so, evacuate all personnel from the immediate area because of the danger from



THIS PAGE INTENTIONALLY BLANK



3. Check that the pilot burner hose is connected correctly to the regulator on the master tank.
4. Check that the vapour valve on the master tank is open.
5. Check that the vapour regulator is not set at too low a pressure, and then attempt to relight the pilot burner.

If unsuccessful, continue the flight using another burner and make a landing as soon as possible. Alternatively, change the vapour hose to another regulator if available and attempt to re-light the pilot burner.

If there is a complete failure of the pilot light system, and the fault cannot be rectified, proceed as follows:

6. Slightly open the main blast valve and ignite the fuel coming out of the main jet ring with a secondary source of ignition.

WARNING: *The peizo system on the burner will not ignite the fuel in this operation. Either matches or a striker must be used.*

7. Once ignition is achieved open the main blast valve fully to gain control of the balloon.
8. Once control is achieved, leaving the main blast valve open, slowly close the liquid withdrawal valve on the fuel tank until the flame is significantly reduced. Do not fully close the liquid withdrawal valve on the fuel tank.
9. To maintain the flight of the balloon, cycle the liquid withdrawal valve on the fuel tank between fully open and nearly closed to control the output of the burner.

NOTE: *It is acceptable to throttle the burner at the main blast valve but freezing of the valve may occur faster than it will at the tank valve.*



Extended flight with the liquid withdrawal valve on a fuel tank partially open may lead to freezing of the valve. Longer periods with the valve fully open will help reduce freezing.

Where extended flight is required until a suitable emergency landing can be made and freezing of the valve is becoming evident, alternating between the tank valve and the main blast valve or other burners/fuel tanks can extend the flight time indefinitely.

CAUTION: *Use of a throttled (partially opened) liquid fire as a pilot light is optional but may produce undesirable spitting of propane/ice.*

3.9 Main Burner Failure

In the event of a main burner failure, several options are available to the pilot.

1. Continue the flight on another burner while troubleshooting the main burner failure.
2. If a single burner is fitted or all main burners malfunction, attempt to use the Liquid Fire.
3. Check for correct fuel pressure indication at the burner.
4. Check the liquid outlet valve is turned on at the correct fuel tank.
5. Check the fuel hose is correctly connected and the connector is fully engaged.
6. Check for fuel quantity indication and fuel quantity by lifting or shaking the fuel tank.
7. Change the fuel line to another fuel tank.
8. If the fault cannot be rectified, prepare for a heavy landing.



NOTE: *Under some conditions generally associated with low ambient air densities, (hot weather or high altitude), a flame instability may develop during continuous burner operation.*

This will first be noticed by a change in tone of the burner sound to a “whoosh” noise. If burning is continued, the flame may be extinguished completely, however this can generally be avoided by terminating the burn at the initial change of sound, leaving the blast valve closed for a short period, then continuing to burn. Further occurrence of this phenomenon can be avoided by using shorter burn periods.



6. Fit the main supply hoses to the liquid outlet valves and pressurize the system.

Warning: *It is important to ensure that there are no leaks in the fuel system before the pilot burners are lit.*

If no leaks are apparent the pilot system can be connected and lit using the piezo igniters.

7. It is recommended that a short burner test on each tank be carried out to ensure a liquid supply from all tanks. This test may be carried out after inflation but prior to flight.

The fuel system should now be shut down for the initial stages of the inflation.

8. The basket should be laid on the side with the burner pointing downwind.
9. The envelope bag is placed downwind of the burner and the bottom portion of the envelope is removed from the bag.

CAUTION: *Total removal of the envelope from the bag is not recommended until after the connection to the basket is made, otherwise a wind gust could partially inflate the balloon and cause it to move downwind, out of control.*

10. The envelope cables are connected to the load frame karabiners in groups as indicated in the following diagram. This will vary depending on the envelope and basket combination.

The Kavanagh Balloons logo will be at the top centre for inflation with the scoop being centred nearest the ground.



SECTION 4 - NORMAL PROCEDURES

4.1 Introduction

This section outlines normal operation procedures. Optional equipment not covered in this section will be covered in Section 9 - Supplements.

4.2 Weather

1. If mandatory, or at the pilot's discretion, obtain a meteorological forecast for the flight area.
2. This can be checked locally before the flight by release and observation of a small helium filled pilot balloon.

4.3 Fuel

1. Check fuel quantity is adequate for the planned flight.
2. Open the fixed liquid level gauge and check for a discharge of liquid propane.

The fixed liquid level gauge (bleed valve) has a dip tube which is long enough to allow liquid to discharge from the valve when the tank is 80% full or over.

3. Weighing is the most accurate way of measuring fuel quantity when the level is higher than that shown on the fuel gauge and lower than the 80% shown by the fixed liquid level gauge.

Note: *LPG weighs .5kg per litre at 16 degrees Celsius so a simple calculation is necessary to determine quantity after the tank is weighed. See Section 6 for tank weights.*

4. Check the fuel pressure is adequate. The effect of temperature on fuel pressure should be appreciated.



4.4 Launch Site Selection

1. Any site selected for take off should be assessed to ensure clearance of downwind obstructions during the initial climb out phase.
2. If the surface wind is above five knots a sheltered site should be considered for inflation.

4.5 Assembly

1. Locate the basket so that when it is laid over for inflation, the burner will be pointing downwind.
2. Slot the four (or eight), nylon flex-frame poles into the sockets in the top edge of the basket and then mount the burner on the poles with the sockets on the burner frame.

The long sides of the burner frame should be in line with the long sides of the basket.

3. The basket suspension cables at each corner of the frame can now be attached to the frame lug with a karabiner.

On most basket models there are two wires per corner with the exception of small light weight baskets which have single corner wires.

On large four point frames there are dual corner lugs of the type which enclose a single wire rope end.

On eight point frames there are four inner attachment points as well as four outer corner attachment points.

The following diagram shows the normal connection arrangements for all types of load frame and basket wire configurations.

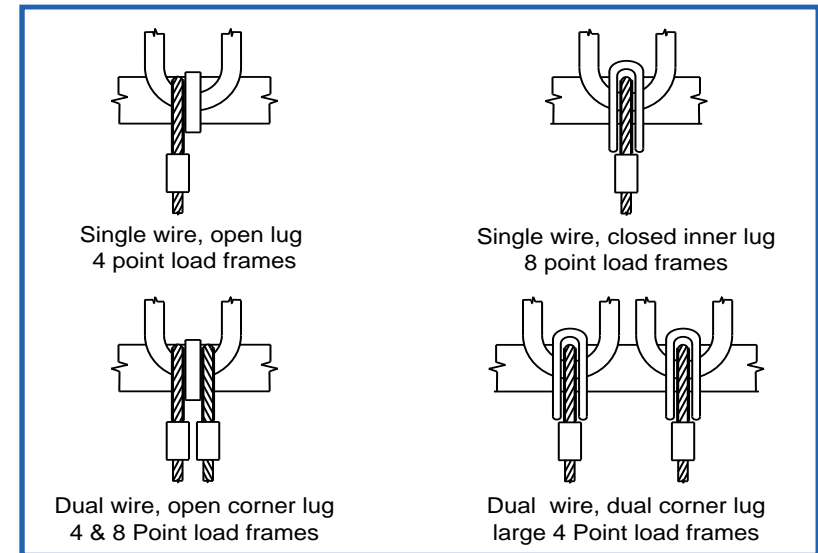

• Basket rigging installation

4. Strap the fuel tanks into the basket, taking care to orientate the master tank to be used for inflation so that the float gauge dial face will be in the upright position when the basket is laid on the side. This will ensure a liquid supply to the burner and vapour to the pilot light.

CAUTION: *If a separate (extra) tank is used for inflation, it must be secured to the basket, so unexpected movement of the basket prior to lift off will not adversely affect the fuel supply from this tank.*

5. Fit the padded flex-frame pole covers. The vapour and liquid hoses may be fitted inside the covers provided there is enough length to reach both tanks on the same side of the basket.

Alternatively, straps on the pole covers are used to secure the vapour and/or liquid hoses to the outside of the pole cover.



5. When the balloon is sufficiently inflated, the pilot can start heating the air with controlled burns from the main burner so that the fabric lifts from the ground.
6. As the balloon continues to fill, allow the fan to do most of the work so that the balloon is full with no bunched fabric on the ground.
7. The crown person should only apply enough weight on the crown line at this time to stop the crown from drifting back towards the basket in calm conditions and almost no weight at all is required if there is any wind.
8. When the balloon is almost completely full on its side, the pilot will signal to the crown crew to apply weight on the line.

WARNING: *If at any time the pilot leaves the controls of the burner during the inflation, the pilot light must be turned off and the fuel system shut down at the fuel tanks.*

9. Finish the inflation with longer burns, until the balloon rises to the upright position.
10. Weight should be applied to the crown line to stop the balloon swinging past the vertical position.

Note: *In calm conditions the crown crew's job is harder than during windy conditions when no pressure on the crown is needed as the wind is quite an effective anchor for the crown.*

4.8 Inflation Notes for Balloons with Lite Vent

The white closing line on the Lite Vent may be used during inflation to re-seat and close the vent panel if the Velcro tabs are inadvertently released.

Alternatively, the Velcro tabs can be intentionally released during the inflation by use of the parachute line and the panel re-centred before the balloon is stood up.

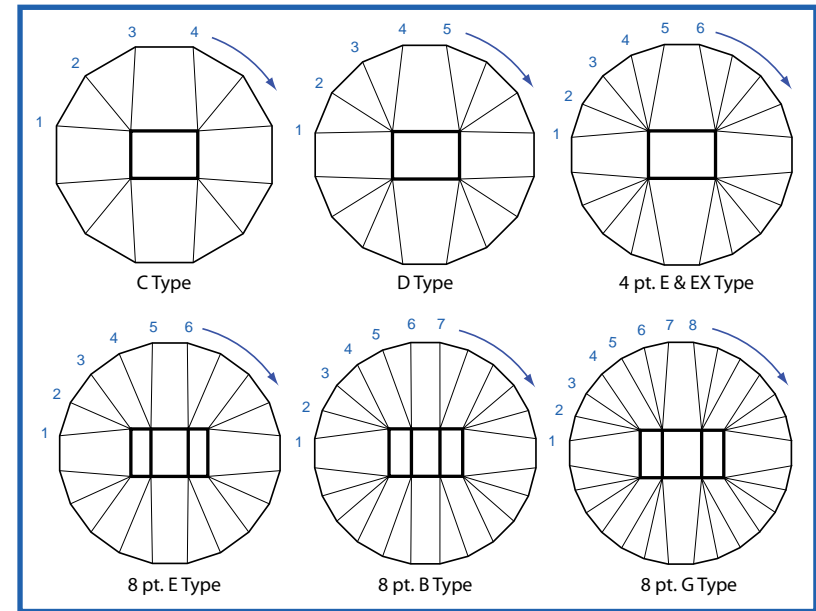

• Envelope rigging layouts

11. Make sure that all the karabiner screwgates are in the closed position.

NOTE: *Backing the screw gates off a quarter turn from the fully closed position will ensure they do not jam in the closed position.*

12. Set the altimeter for correct QNH or QFE setting and check the electric variometer and temperature gauge for indication of correct operation, ensuring the cable connection to the envelope, (if applicable), is secure.
13. Connect the deflation system and vent control lines to the basket at the appropriate places.

If a Parachute Vent is fitted the activation rope is coloured red & white.



If a Smart Vent is fitted, the centre pull rip line is red and the parachute/reset rope is coloured red & white.

If a Lite Vent is fitted, the parachute vent rope is red & white, the closing rope is white and the centre pull rip line is red.

If a Velcro rip panel is fitted the rip line is coloured red.

14. Connect the rotation vent cords to the load frame or basket. The rotation vent cords are coloured green for the right turn and black for the left turn. When facing outwards from the basket, the cord on the right will turn the balloon to the right and the cord on the left will turn the balloon to the left.
15. If an inflation safety restraint, (quick release tie off), is to be used, it should be fitted before inflation of the envelope begins.

For balloons 140 and smaller, the release bridle should be tied around the base of the flex frame poles and basket wires at the top edge of the basket.

Alternatively, the quick release may be attached to the top envelope karabiners either directly at one corner of the load frame or with a vee bridle to the two upper corners.

For larger balloons, the best attachment point is on the top centre set of envelope karabiners at the load frame or to the basket frame launch lugs if fitted.

WARNING: Any launch restraint connected at the flying wires presents a risk to the pilot if it puts the release mechanism at face level. Care must be taken to ensure that the pilot is not struck by the release when it is operated.

16. Drag the envelope out of the bag and ensure the crown line is untangled along the full length.



4.6 Pre-Inflation Checks

1. Re-check all the points made in 4.5 of this manual.
2. Check that at least one extra source of ignition for the pilot burner is in the basket, ie. striker or matches or both.
3. Check that all mandatory equipment such as handling line and fire extinguisher is on board as well as any other equipment to be carried.
4. Make a detailed check of the load to be carried against the instructions set out in SECTION 5.
5. Check that the weather conditions are still as expected for the flight and that it is safe to proceed with the inflation.

4.7 Inflation - Recommended Procedure

Although the inflation can be carried out by only the pilot in suitable conditions, it is recommended (but not mandatory) to have adequate crew to assist at the following locations.

One crew member on the crown line, one crew member on each side of the mouth to hold it open during filling with the fan. One crew member to operate and control the inflator fan.

1. The fan is started and at this point the balloon pilot, should walk into the balloon taking all the excess length of vent and reset ropes to above the lower pulleys.
2. As the balloon inflates the pilot should visually inspect the condition of the envelope and ensure that the vent rope and the rigging are not in a position to tangle as the inflation progresses.
3. For Parachute Vent, Smart Vent and Lite Vent, attach all of the temporary vent tabs on the vent panel as the balloon inflates.
4. For Circular Velcro Rip Panels, ensure all Velcro tape is secure and that all rip locks have been installed and secured as required in section 4.14.



2. While looking up to watch the reaction of the vent and balloon, pull the parachute line to release air from the balloon.
3. Release the parachute vent line and look up again to see that the vent has properly closed.
4. In the event that the vent panel has not returned as expected, the burner should be immediately operated to push the panel in place.

For a Smart Vent, a light tug on the parachute line will help extend the panel to cover the vent opening.

For a Lite Vent, the vent panel may be fully extended and closed using the white closing line.

NOTE: *The envelope should be observed for excessive deformation during use of the vent. Always refer to the limitations section for in-flight venting.*

CAUTION: *The parachute action of the Lite Vent deflation system is significantly improved over other deflation systems. Extreme care should be taken while gaining experience with its use until the pilot is familiar with the performance of this system.*

4.11.2 In-flight Venting - Circular Velcro Rip Panel

Balloons fitted with a Circular Velcro Rip Panel will use the rotation vents for a controlled release of hot air to initiate a descent or arrest a climb.

1. Pull on both rotation vent lines at the same time to release hot air from the balloon. Opening both vents at the same time will prevent the balloon from rotating.
2. Release the rotation vent lines and visually check that the vents have closed.



1. Carefully pull the white closing line ensuring the reset weight and pulleys are free from fabric.
2. Once the vent is covering the vent hole, have a crew member hold the vent in position with the white rope.

CAUTION: *Do not tie the white rope off at the load frame or basket for the inflation. As the balloon changes shape, the white rope will need to be released into the balloon or damage may occur.*

3. Continue the inflation as normal while ensuring that excessive tension is not being applied to the white closing line.

4.9 Pre-Launch Checks

1. Before fully heating the balloon to flight temperature, release all of the Velcro tabs around the outer edge of the vent panel by use of the parachute line. Ideally, the parachute should be activated enough to rotate the vent panel so the Velcro tabs are no longer aligned.
2. For balloons with a Smart Vent or Lite Vent, the deflation system can be tested, by first pulling the red rip line, then resetting the vent panel using the red & white parachute line.

Note: *The panel does not need to be fully opened. Open the panel just enough to check all lines are running freely.*

3. For balloons with a Lite Vent, check the panel is fully extended by pulling on the white closing line.
4. Stow all control lines ensuring that they are not in a position to be activated unintentionally or at risk of being jammed under fuel tanks.



WARNING: For balloons fitted with the Smart Vent deflation system, the red & white vent line must be fed into a pouch to ensure it is free to run up into the balloon during operation of the centre pull rip line. If the parachute line is jammed the vent will not open as expected.

WARNING: For balloons fitted with a Lite Vent, the white closing line must be fed into a pouch to ensure it is free to run up into the balloon during operation of the centre pull. If the white closing line is jammed the vent will not open as expected.

5. Check the operation of the rotation vents is normal and that no lines are tangled or that the rotation vents are being held open.
6. Visually inspect the envelope for any damage.
7. Visually inspect all flying wires are not twisted or damaged.
8. Check all karabiners at the load frame are correctly aligned and screw gates closed.
9. Check that both fuel supply hoses are delivering fuel satisfactorily and that all pilot lights are operational.
10. Ensure that passengers are properly instructed and have been briefed on the correct landing position.
11. Make an extra check that all points in this section have been satisfied.

4.10 Launch

1. If a pilot restraint is fitted, it should be worn by the pilot for take off and low level flight. It is advisable that it be worn for the duration of the flight.
2. Check for down wind obstacles and changes to meteorological conditions that would be cause to terminate the flight.



3. Heat the balloon to positive buoyancy taking into account any "False" lift due to ground wind.
4. If a launch restraint is in use, ensure crew and people on the ground are well clear of the launch rope before activating the release.

Ensure the launch restraint is as lightly loaded as possible when it is released.
5. Maintain a steady rate of climb to clear all obstacles and establish control of the balloon.

4.11 Flight

Flight of the balloon requires controlled inputs of heat from the burner to counter the natural cooling of the envelope.

An excess of heat above the amount required for level flight will result in a climb, while less heat will result in a descent.

The use of vents in flight to arrest climbs, initiate descents or rotate the balloon is normal but will increase fuel consumption and as such is best to be avoided unless necessary.

4.11.1 In-flight Venting - Parachute Operation

The parachute vent, aside from being a dedicated system, is incorporated into the Smart Vent and Lite Vent deflation systems for use in flight to allow controlled release of hot air to initiate a descent or to arrest a climb.

Care should be taken to ensure that excessive or unintentional descents are not generated by use of in-flight venting and the pilot should become familiar with the effect of the vent when used in flight.

It is good practice to always look up at the balloon when operating a vent to ensure that the correct line has been activated and that the desired action is taking place.

1. The parachute line is a red and white striped line.



4.11.9 Use of Fuel Tank Manifolds

Fuel tank manifolds may be used to connect several tanks to one burner fuel supply hose. This reduces the need to change hoses from one tank to another.

1. Care must be taken to ensure only one tank is supplying each burner at any one time in order to maintain good awareness and control of fuel usage.
2. If one arm of a fuel manifold is not connected to a fuel tank, the free end must be capped with a blank connector to prevent damage to or failure of the self seal in the hose end connector.

4.11.10 Pilot Restraint Harness

If a pilot restraint harness is fitted, it should be worn during take off and for the duration of the flight including the landing.

1. The harness is a waist belt with a push button seat belt buckle to allow quick release if needed.
2. Fit and adjust the harness so it is a snug fit around the waist, above the hips, with the release button located at the front.
2. An adjustable strap connects the harness to the anchor point in the basket. With the strap at full length, the pilot will be able to move freely around the pilot compartment.
4. The restraining strap should be shortened to restrict the movement of the pilot within the compartment in preparation for the landing. This will maintain the correct pilot position during the landing.



NOTE: *The use of rotation vents for in-flight venting is not as effective as the parachute system. The vents may need to be held open for a longer than usual period to achieve the desired control input.*

4.11.3 Lite Vent Closing Line

The Lite Vent deflation system has a white closing line to allow the pilot to fully extend the vent panel to cover and seal the vent hole.

1. If the vent panel appears to be off centre or leaking, the white closing line should be pulled to adjust the vent panel position.
2. If severe turbulence is encountered during flight the Lite Vent panel can be securely held in place to prevent leakage, by application of a little force to the white closing line.
3. During high rates of climb in "EX" model balloons, the white closure line can be used to ensure the vent is closed and sealed after operation of the parachute vent line.

4.11.4 Rotation Vents

Rotation Vents may be used in flight to orient the balloon as the pilot wishes.

1. The green control line will rotate the balloon to the right.
2. The black control line will rotate the balloon to the left.
3. The opposite rotation vent can be used to stop the rotation of the balloon or the balloon can be left to slow down and stop rotating naturally.

NOTE: *Excessive use of the rotation vents will cause a significant rise in fuel consumption.*



4.11.5 Burner Operation - Main Burner

1. The burner will be most effective if used in short burns at short intervals for greater control of vertical movement.
2. The valve should be cycled from fully closed to fully open and back to fully closed to ensure proper operation of the burner.
3. The normal operating range of the burner is 350-1500 KPA.

NOTE: *If a main burner is run on vapour, the flame becomes shorter and louder and a reduction of delivery pressure will be indicated on the pressure gauge.*

CAUTION: *The main burners are designed to run on a supply of liquid propane. If they are operated on propane vapour, the burner will overheat and may be permanently damaged.*

4.11.6 Burner Operation - Liquid Fire

1. The liquid fire may be used in addition to or independent of the main burner. It has both reduced noise levels and output levels compared to the main burner.
2. The valve may be metered (partially opened) provided the flame stability and condition is monitored. This is particularly useful over sensitive livestock or property.

Note: *Excessive use of the liquid fire may cause a carbon build up on the inside of the envelope and this will affect the appearance of the balloon.*

CAUTION: *Extended operation of a partially opened valve may result in refrigeration of the valve. If freezing becomes evident the valve should be fully opened for a short time before being closed and allowed to return to ambient temperature.*



4.11.7 Fuel Management

1. Each pilot must have a fuel management system appropriate to the flight plan and fuel tank/burner/basket configuration.
2. The only suggested procedure is to ensure there is an adequate fuel supply available to each fuel supply hose at all times during flight, so if an emergency need for maximum power arises, there will be fuel available to all burners in sufficient quantity to meet the need.

NOTE: *Better fuel consumption will be obtained if vertical speed is kept to a minimum.*

4.11.8 Fuel Tank Hose Change

1. Check the function of the alternate fuel supply and ensure the balloon is climbing or at a safe height above the ground.
2. Shut off the empty fuel tank and empty all fuel from the hose before disconnecting from the tank.
3. Re-position the hose to the new fuel tank and connect the hose.
4. Check the fitting is tightened securely and fully engaged, also ensure the fuel line is properly secured.
5. Turn on the fuel supply and test the burner on the new fuel supply.



NOTE: *In all cases, releasing the parachute line may allow the vent to close and will prolong or prevent the deflation of the balloon. In fast landings, this may greatly increase the distance the balloon drags across the ground before stopping.*

CAUTION: *Using the parachute mode for final landing with both Smart Vent and Lite Vent, the deflation time may be increased over the time expected with a standard parachute vent, therefore it is not recommended to use this technique with these deflation systems.*

WARNING: *In landings with a high rate of descent there is a possibility of rebound after contact with the ground. This rebound may be transferred to the parachute line and pilots must be holding on securely as there is a significant risk of being pulled from the basket by the parachute line in this situation.*

4.14.2 Final Landing - Smart & Lite Vent

Deflation of the balloon during final landing with a Smart Vent or Lite Vent is generally very fast and will normally require a much smaller area to land the balloon than it does for a balloon fitted with other deflation systems.

1. The red centre pull rip line should be fully opened once the balloon is within six feet (2 metres) of ground level at the pilot's discretion during the landing operation.
2. A small amount of load should be held on the rip line to ensure the vent will stay fully open during the deflation.

NOTE: *Due to the rigging of these deflation systems, any rebound on landing will not be transferred to the red rip line. However, the pilot should still be hanging on securely during the landing.*

3. Once the balloon has stopped and is fully deflated, the pilot must check to ensure all the fuel valves are turned off and that fuel pressure is released from all parts of the fuel system.



4.12 Approach to landing

1. A suitably large landing site should be selected, free of obstacles such as power lines, buildings and livestock. The overshoot area (down wind of the landing) should be free from high obstacles where possible in case the landing has to be aborted.
2. When horizontal landing speed is expected, passengers should be made aware that the basket may tip forward and they should take a lower than normal landing position to avoid being thrown forwards out of the basket
3. When a fast landing is anticipated extra space will be required for the potential drag and deflation of the balloon and a low approach should be favoured to minimise the vertical speed during landing.
4. Crew and passengers should be briefed for the landing and safe landing positions confirmed well in advance of the touchdown.
5. Particularly in partitioned baskets, rotation vents must be used to orient the basket so that the long side of the basket is across the direction of travel.
6. Just prior to touchdown, the vertical speed of the descent should be minimised with the use of the burner. The pilot lights and main burners **must** be extinguished before ground contact is made.

NOTE: *If an intermediate landing is to be carried out, the scoop should be positioned down wind during the landing.*

WARNING: *Landing a partitioned basket on a corner or short edge presents considerable risk to the occupants. Any landing where the basket is out of position should be aborted unless it is an emergency landing.*



4.13 Intermediate Landing

If the wind speed on the ground is slow enough and the landing site has adequate space for a re-launch, the balloon may be kept inflated to change passengers or to upload more fuel before continuing the flight.

The balloon may also be landed using the following technique to allow assistance from ground crew with deflation or moving of the balloon to a more suitable position for deflation.

WARNING: *Any time the balloon is on the ground and not secured with a launch restraint, there is considerable risk to personnel and equipment due to unexpected wind gusts or changes in loading. Care must be taken to minimise this risk.*

4.13.1 Intermediate Landing - Parachute Vent.

The following procedure can be used with a standard parachute vent as well as the parachute action on a Smart Vent or Lite Vent.

1. Prior to ground contact, open the parachute vent sufficiently to stop the balloon from dragging.
2. When the balloon is safely on the ground and before too much lift is released from the balloon, release the parachute line to close the parachute vent.
3. If required, re-ignite the pilot light and re-fill the balloon using the burner until the envelope is stable without lifting off again.

4.13.2 Intermediate Landing - Smart & Lite Vent

1. Just prior to ground contact and not more than 6 feet from the ground, fully open the Smart/Lite Vent using the red rip line.
2. After initial ground contact, and before too much lift is lost from the balloon, close the Smart/Lite Vent using the red and white parachute line.

A fast pull on the parachute line will enable the vent panel to re-



inflate with the out rushing air, and the parachute line can then be released to seal the vent.

3. If required, re-ignite the pilot light and re-fill the balloon using the burner until the envelope is stable without lifting off again.

NOTE: *To reduce rebound on landing and to assist in shortening the landing drag, the Smart/Lite Vent should be fully opened and should remain open until the initial rebound of air inside the balloon has reached the top of the balloon.*

4.13.3 Intermediate Landing - Rip Panel

Intermediate landings using a rip panel are not recommended as the amount of lift that can be released with the rotation vents alone is not likely to be sufficient to make a safe intermediate landing. Exceptionally calm conditions would be the only conditions where an intermediate landing could be attempted.

4.14 Final Landing

A final landing generally includes the intention to fully deflate the envelope immediately after touchdown. A final landing ensures that the risks associated with an inflated but unrestrained balloon are minimised.

4.14.1 Final Landing - Parachute Vent

The following procedure can be used with a standard parachute vent as well as the parachute action on a Smart Vent or Lite Vent.

1. Prior to ground contact, open the parachute vent sufficiently to ensure the balloon makes contact with the ground.
2. During the touchdown, continue pulling the parachute line to increase the opening and hold the vent open until full deflation of the envelope occurs.
3. Once the balloon has stopped and is fully deflated, the pilot must check to ensure all the fuel valves are turned off and that fuel pressure is released from all parts of the fuel system.



THIS PAGE INTENTIONALLY BLANK



4.14.3 Final landing - Circular Velcro Rip Panel

Final landing with a Circular Velcro Rip Panel is absolutely final as the deflation panel has to be manually reset once the balloon is empty.

1. Prior to contact with the ground the red rip line should be pulled to release the lower safety Velcro at the bottom pulley. The excess rope should be pulled into the basket in preparation for the landing.
2. Once committed to the landing spot but not higher than 6 feet above ground, the rip panel can be opened using the red rip line.

NOTE: *At each rip lock the load on the red rip line may increase. A short sharp pull on the line will assist in opening the lock.*

CAUTION: *The speed and amount that the rip panel opens is dependent on the speed with which the pilot pulls the deflation line. In many cases the balloon may come to a complete stop before the panel is fully open.*

3. Once the balloon has stopped and is fully deflated, the pilot must check to ensure all the fuel valves are turned off and that fuel pressure is released from all parts of the fuel system.
4. Prior to packing the envelope, the rip panel should be re-installed as per 4.15.



4.15 Install the Circular Velcro Rip Panel

To ensure there is no unnecessary wear on the balloon and to keep the Velcro of a rip panel clean, it is recommended that the panel be re-sealed prior to packing the envelope.

1. Carefully pull the red rip line back to the top of the balloon so there is enough excess to fit the rip panel.
2. Starting at one end of the rip panel, align the first two vertical tapes so the Velcro can be sealed along the horizontal seam.

NOTE: *The Velcro is pressure sensitive so more pressure will make a better seal.*

3. Ensure the alignment of the seal is good and repeat for all gores of the rip panel.
4. Return to each rip lock and open just enough Velcro to allow access to the rip lock from outside of the balloon.
5. Install the lock into the loop on the envelope and secure each lock to the adjacent D ring on the envelope with two turns of nylon thread (KP2603) or a similar thread with a breaking strain of 5kg.
6. Re-close the Velcro where required.

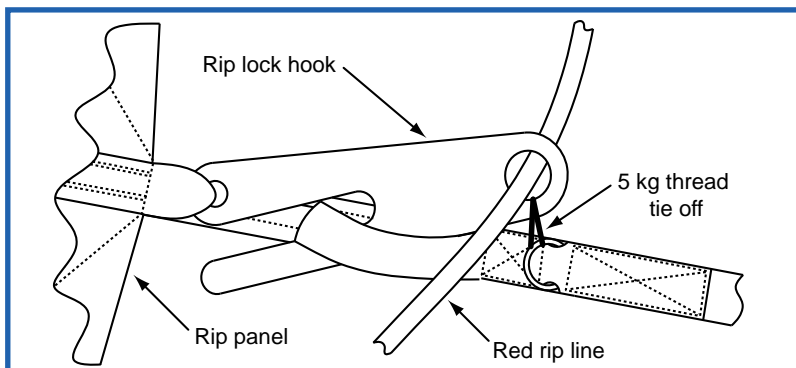

• Rip lock installation



7. Secure the rip line at the pulley near the mouth of the balloon using the length of Velcro below the pulley.

NOTE: *During the next inflation all rip locks will need to be checked for correct orientation and security before the balloon is stood up.*

NOTE: *This Velcro closure at the lower pulley ensures there is enough spare rip line inside the envelope to allow for any distortion in flight and also provides a direct and audible warning if the rip line is inadvertently activated at any time.*

**SECTION 5 - PERFORMANCE****5.1 Calculation of Payload****Instructions for use of the Load Chart**

1. Determine the ambient temperature at takeoff site.
2. Determine the height (above sea level) of the take off site, and set the altimeter sub scale to 1013 millibars. If the altitude shown is greater than the height of the actual take off site, this difference must be added to the planned maximum altitude. If the altimeter shows a lesser height, the difference should be subtracted from the planned maximum altitude. This calculation allows for daily differences in atmospheric pressure.
3. Decide maximum planned flight altitude.
4. Enter the load chart graph (Section 5.2) at ambient temperature scale and move vertically to altitude of takeoff site.
5. Move diagonally, (parallel to I.S.A. line) to the maximum planned flight altitude.
6. Move horizontally across to the gross lift scale at the left side.
7. Read off gross lift in kg per 1000 cu.ft from the scale at this point.
8. Multiply this weight by the balloon model number to calculate the maximum gross lift for the planned maximum flight altitude. Example: For an E-120 you would multiply the gross lift per 1000 cu.ft by 120 to calculate the maximum gross lift.
9. Follow the loading system described in Section 5.3 to determine the available load.

THIS PAGE INTENTIONALLY BLANK



5.2 Lift Chart

Gross lift per 1000 cu. ft.
Envelope temperature: 100 Degrees Celsius
I.S.A. conditions

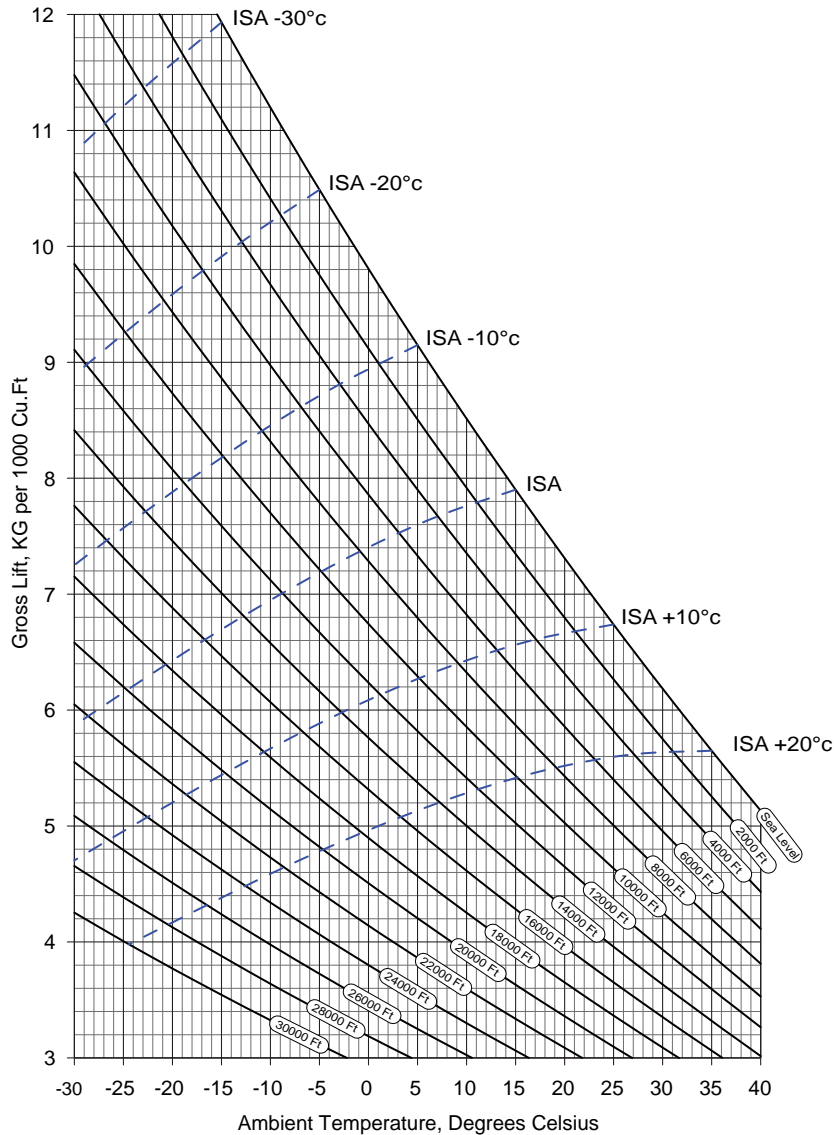

This page CASA approved



5.3 Loading System

The following is the loading system for all Kavanagh Balloons.

Use of this system will determine the available excess load based on the planned flight details.

The available load must be greater than or equal to zero to ensure the certificated climb performance can be achieved without exceeding the envelope temperature limitation in Section 2.3.

1	Envelope Gross Certificated Weight (Section 2.1)	<input type="text"/>	Enter the lower of the three figures from 1,2 or 3 (A) <input type="text"/> This is the maximum weight for this flight.
2	Basket Gross Certificated Weight (Section 7.2)	<input type="text"/>	
3	Gross lift as calculated in Section 5.1	<input type="text"/>	
5	Total envelope, basket & burner weights (Section 6.1)	<input type="text"/>	(B) <input type="text"/> Total of 5,6,7 & 8
6	Total fuel weight at takeoff (Section 6.2)	<input type="text"/>	
7	Total pilot weight including any accessories or luggage.	<input type="text"/>	
8	Total passenger weights including any accessories or luggage.	<input type="text"/>	
9	Remaining load capacity - this figure must be greater than, or at least equal to zero.	<input type="text"/>	(C) <input type="text"/> A - B = C

This page CASA approved



Some balloons may have more Nomex in panel 2 or three as a customer option.

A scoop skirt constructed from nomex is optional and is fitted to the downwind side of the balloon mouth to assist with launching and tethering in windy conditions.

7.2.1 Type B Balloons

Type B envelopes have 24 gores and are available in 77, 105, 350 and 400,000 cubic foot models. The Smart Vent deflation system is standard on the 77 and 105 models with a Parachute Vent or Lite Vent being available as an option.

The 350 and 400 are fitted with the Lite Vent as standard with a Circular Velcro Rip Panel as an option on these two models.

7.2.2 Type C Balloons

Type C envelopes have 12 gores and are available in 56, 65 and 77,000 cubic foot models. The Smart Vent deflation system is standard with a Parachute Vent being available as an option.

7.2.3 Type D Balloons

Type D envelopes have 16 gores and are available in 77, 84, 90 and 105,000 cubic foot models. The Smart Vent deflation system is standard with a Parachute Vent being available as an option.

7.2.4 Type E Balloons

Type E envelopes have 20 gores and are available in 120, 140, 160, 180, 210, 240, 260 and 300,000 cubic foot models. The Smart Vent deflation system is standard on all models up to the E-160.

The Lite Vent deflation system is standard on the E-180 to E-300 models, but may be fitted as an option to E-120, E-140 or E-160 models as an option.

7.2.5 Type EX Balloons

Type EX envelope has 20 gores and is available in a 65,000 cubic foot model. The design of this balloon allows higher than average rates of



SECTION 6 - WEIGHTS

6.1 Weights

		Weight in KG.
Envelope:	Model: _____	[]
	Serial No.: _____	

Envelope weight includes the following:

Envelope Sub Total: []

Basket:	Model: _____	[]
	Serial No.: _____	

Basket weight includes the following:

Burner:	Model: _____	[]
	Serial No.: _____	

Load Frame:	Model: _____	[]
	Serial No.: _____	

Bottom End Sub Total: []

TOTAL WEIGHT: []

Envelope Carry Bag:

Signed: _____ Date: _____

Aircraft Weight Control Authority No: _____

This page CASA approved



6.2 Fuel Tank Weights

Table 4 - Fuel tanks with AFL's

Description	Empty Weight	Full Weight
Kavanagh 55, Master	21	43
Kavanagh 55, Slave	20.1	42.1
Kavanagh 76, Master	23.3	53.7
Kavanagh 76, Slave	22.5	52.9
Kavanagh 82, Master	24.6	57.4
Kavanagh 82, Slave	23.7	56.5

Table 5 - Fuel tanks without AFL's

Description	Empty Weight	Full Weight
Kavanagh 55, Master	20.5	42.5
Kavanagh 55, Slave	19.2	41.2
Kavanagh 76, Master	22.9	53.3
Kavanagh 76, Slave	21.6	52
Kavanagh 82, Master	24.2	57
Kavanagh 82, Slave	22.9	55.7
Worthington 47 Master	15.3	34.3
Worthington 47 Slave	14	33

NOTE: *Weights are in Kg and all tank weights include padded jackets, and handle guards.*



SECTION 7 - SYSTEM DESCRIPTION

7.1 Introduction

This section describes the standard components and assemblies which make up a Kavanagh hot air balloon. Equipment lists covering standard components and approved combinations are contained in 7.12. Additional equipment or options are found in Section 9 - Supplements.

7.2 Envelope

The envelope is the major component of the aircraft. There are six types of Kavanagh Balloon and these types cover a range of models from 56,000 cubic feet to 450,000 cubic feet in volume.

All envelopes are of the bulge gore design with the C,D and E types having a more pronounced bulge than the B, EX and G types. The gores have a tailored excess of fabric horizontally between each vertical load tape.

The EX type balloon is a dedicated competition design with a greater height to diameter ratio to improve vertical performance and stability at higher rates of climb and descent.

All balloon envelopes are manufactured from high tenacity rip-stop nylon fabric which is coated so that the whole structure remains as airtight as possible.

All the major loads are taken on polyester webbing both horizontally and vertically. These load tapes allow for a wide margin of safety as well as providing suitable anchor points for the attachment of payload.

The payload is connected via stainless steel wire rope "flying wires" from each of the vertical load tapes.

Panel 1 is constructed using Nomex to ensure that the nylon fabric is not exposed to excessive heat from the burner.



balloon will deflate rapidly. This final deflation mode is known as the centre pull mode.

Refer to the limitations section of this manual for operation of the rip line.

The Lite Vent can also be re-set or closed after the centre pull has been activated. The re-set is achieved by releasing the rip line and pulling on the red & white parachute vent line until the vent panel is fully extended and covering the hole. The vent line is then released and air pressure will seal the vent.

Re-setting the vent in this way is made easier if a) the centre pull is fully activated before the re-set is started and b) a swift pull on the vent line achieves full inflation of the vent panel before it is in full contact with the overlying load tapes.

The third control line on the Lite Vent is the white closing line. The closing line is used to physically ensure the vent is held closed in the event of the vent panel becoming displaced during inflation of the balloon, after re-setting the vent in an

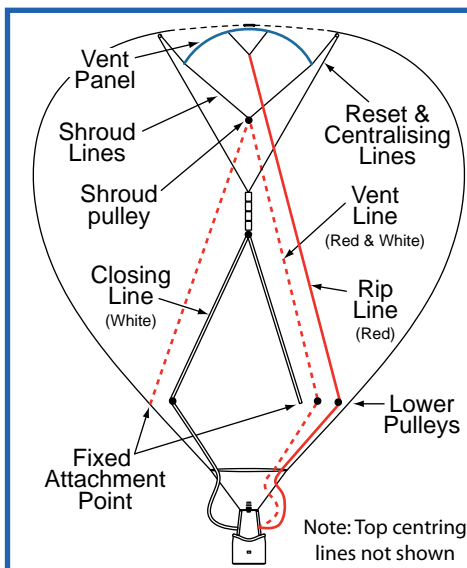

• Lite Vent - parachute mode

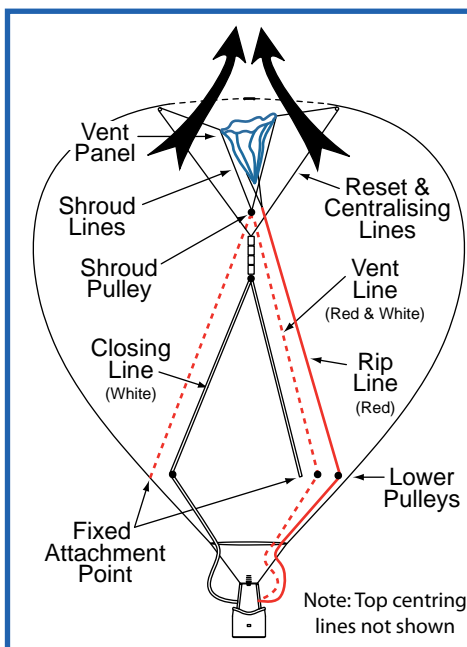

• Lite Vent - centre pull mode



climb and descent for competition use. The Lite Vent deflation system (without centre pull) is standard on this model.

7.2.6 Type G Balloons

Type G envelope has 28 gores and is available in a 450,000 cubic foot model. The Lite Vent deflation system is standard on this model.

7.2.7 Parachute Vent

The parachute vent allows the controlled release of air from the balloon while in flight and also total deflation of the balloon during landing.

The parachute deflation system consists of an oversized circular panel that sits below a circular hole in the top of the balloon.

The panel is held in place by internal air pressure in the balloon and is located radially by the centralising lines that are connected from the outside edge of the vent panel to the inside of the envelope.

The parachute vent is operated by pulling the red and white rip line which through a series of pulleys, pulls down on the shroud lines that are connected to the edge of the vent panel.

Final deflation is achieved by holding the parachute vent firmly open with the rip line until the balloon is empty.

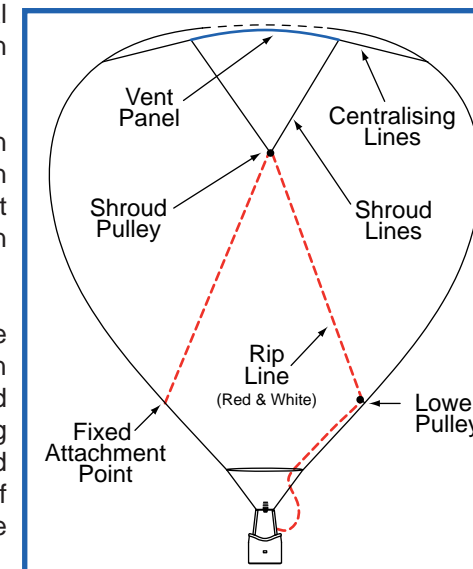

• Parachute Vent



7.2.8 Smart Vent

The Smart vent deflation system is a fast deflation system that also incorporates the manoeuvring vent for in-flight venting in one simple to use system.

The Smart Vent is generally fitted to balloons smaller than 180,000 cu.ft in volume.

The vent consists of an oversized circular panel, which sits below a hole in the top of the balloon and is held in place by internal air pressure in the balloon and radially by a series of reset/centralising lines as well as the top centring lines.

It is operated using either one of two control lines, which are fed through a system of pulleys to the basket.

In-flight venting is achieved by pulling the red & white vent line so that the outer edge of the vent panel is pulled downwards, allowing a controlled release of air. This in-flight venting method is also known as the parachute mode due to the similarity in operation to a standard parachute vent.

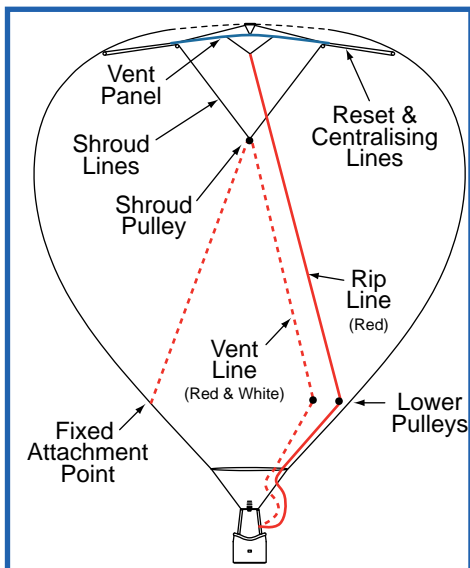

• Smart Vent - parachute mode

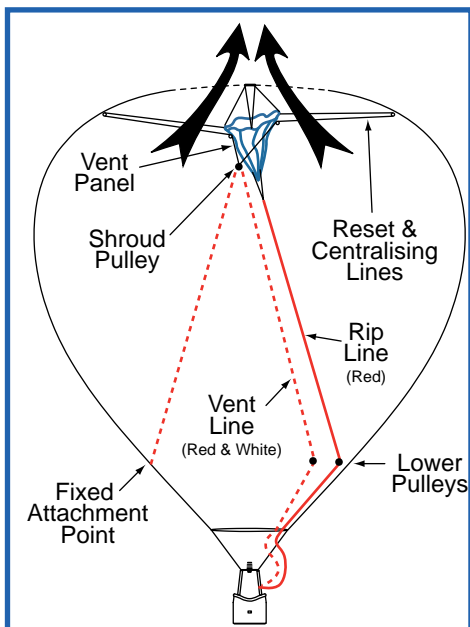

• Smart Vent - centre pull mode



For final landing, the red rip line is pulled so that the centre of the circular panel is pulled down into the balloon while radially diminishing the size of the panel. The majority of the hole will be uncovered and the balloon will deflate rapidly. This final deflation mode is known as the centre pull mode.

Refer to the limitations section of this manual for operation of the rip line.

The Smart Vent can also be re-set or closed after the red centre pull rip line has been activated. The re-set is achieved by releasing the rip line and pulling on the red & white vent line until the vent panel is fully extended and covering the hole. The vent line is then released and air pressure will seal the vent.

7.2.9 Lite Vent

The Lite Vent deflation system is a fast deflation system that also incorporates the manoeuvring vent for in-flight venting in one simple to use system.

The Lite Vent is generally fitted to balloons 180,000 cu.ft in volume or larger and has an improved parachute action for use in large balloons. The vent consists of an oversized circular panel, which sits below a hole in the top of the balloon and is held in place by internal air pressure in the balloon and radially by a series of closing/centralising lines which are attached to a reset weight.

In-flight venting is achieved by pulling on the red & white parachute vent line which pulls down on the edge of the vent panel for a controlled release of air. Releasing the vent line will allow the panel to close due to internal air pressure. This is known as the parachute mode.

Due to the parachute action of the Lite Vent deflation system being significantly improved over other venting systems, extreme care should be taken during in-flight venting. It is advised that pilots "look up" to monitor the size of the opening whilst gaining experience with the system.

For final landing, the red rip line is pulled so that the centre of the vent panel is pulled down into the balloon while radially diminishing the size of the panel. The majority of the hole will be uncovered and the



walls separating passengers are made from plywood bolted to the top frame and the plywood floor.

Alternately, partitioned baskets may have flexible passenger partitions made from a net of vertical wire ropes and horizontal aluminium bars covered in foam padding.

Partitioned baskets are fitted with back padding in passenger compartments as a minimum level of comfort and safety.

All baskets will have internal rope grab handles for the pilot and passengers as well as external rope handles for ground handling.

To assist in supporting the load frame and burner during inflation and landing, there are four (or eight), nylon flex frame support poles which fit into stainless steel sockets on both the burner load frame and the top edge of the basket. These poles and the rigging are then covered with padded pole covers.



• **Double tee partitioned basket**

The bottom edges of the basket are covered with tough chrome hide to prevent scuffing the wickerwork and the edge of the floor. The top edges of the basket are covered with cushioned leather for passenger comfort.

As standard the basket has a 1kg dry powder type fire extinguisher and handling line.



intermediate landing or if severe turbulence is encountered in flight. The closing line is for final adjustment of the vent panel and is not for re-setting the vent after activation of the red centre pull rip line.

The closing line attaches to the reset weight bag inside the balloon. Shroud lines run to the edge of the vent panel via pulleys on the inside surface of the balloon near the edge of the vent hole.

Pulling on the closing line extends the edge of the panel radially and also holds the panel up against the hole in the top of the balloon to minimise leakage.

7.2.10 Circular Velcro Rip Panel

The Circular Velcro Rip Panel is a final deflation system only. The rip panel consists of a circular panel, permanently attached to the balloon around approximately one quarter of its circumference.

The remainder of the rip panel is secured with two piece Velcro tape. Mechanical locks are positioned on vertical load tapes at various points around the opening to transfer loads from the panel to the vertical load tapes and to prevent inadvertent opening of the rip panel while in flight.

The red rip line is the only control line for the system and it runs in a single length from the basket to each of the rip locks in sequence around the rip panel.

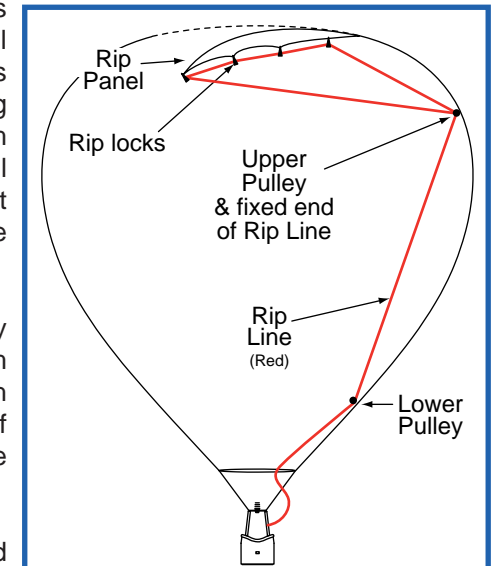

• **Circular Velcro Rip Panel**

Final landing is achieved by pulling the red rip line to first break the Velcro safety strap at the lower pulley, then the first rip lock at the rip panel. Once the first rip lock is released, continued pulling on the rip line will separate the Velcro and all subsequent rip locks in turn until the full



length of the rip panel is opened and the edge of the rip panel is draw stringed together.

Once activated the rip panel will not close and as such the balloon will be committed to a landing.

Refer to the limitations section of this manual for operation of the rip line.

In-flight venting is achieved by simultaneous operation of both rotation vents.

7.2.11 Rotation Vents

Rotation vents are optional on all balloons up to an E-160 and are standard on all larger sizes.

Refer to the limitations section for information on basket configurations requiring the envelope to have rotation vents.

Rotation vents allow the pilot to rotate the balloon in either direction and are useful to maintain the orientation of the long side of the basket across the direction of travel during the landing.

The ends of the two activation cords are 25mm wide webbing. One is coloured green and the other is black.

When facing outwards from the basket, the green strap is to the right and will cause the balloon envelope to rotate to the right, while the black coloured strap will cause it to rotate to the left.

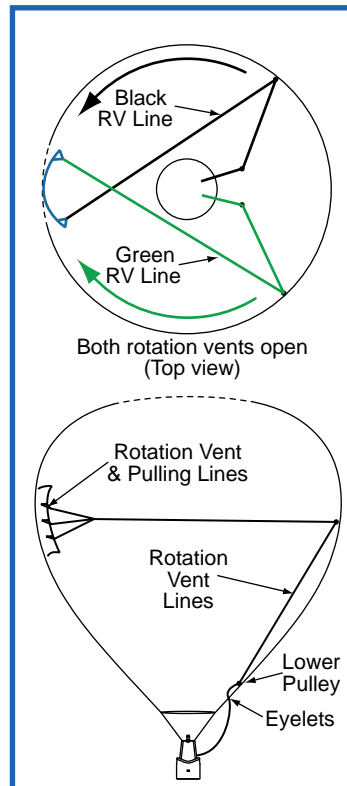

• Rotation vents



7.2.12 Scoop Skirt

The scoop is a nomex extension attached at the mouth of the balloon to assist in pressurising the envelope during launch or tether operations. The scoop may also act as a shield for the burner when passing through wind shear in flight.

Typically the scoop covers approximately half of the circumference of the mouth and tapers down to the load frame on the outside of the flying wires.

The scoop is optional, but highly recommended.



• Scoop Skirt

7.3 Basket

Baskets may be partitioned or unpartitioned and have either a woven or plywood floor. In all cases the basket suspension system consists of stainless steel wire rope slings, which pass through the sides and under the floor of the basket and connect to each of the four (or eight) suspension attachment points on the burner load frame.

All partitioned baskets have a plywood floor and are constructed of cane woven around an upper stainless steel tubular frame and lower cane or stainless steel tubular frame. The lower frame is then laced to the floor.

Bolted to the underside of the floor are four hardwood runners, which protect the floor from damage during landing and ground handling. Unpartitioned baskets may be fully woven with a cane and timber slat floor or they may be fitted with a plywood floor.

Partitioned baskets have transverse internal walls woven from cane and the



• Open Basket



7.5.4 Cross Flow Valve

Multiple burner systems may have an interconnecting pipe and isolating valve called a cross flow valve. With the cross flow valve open, operation of the main valve on one burner valve will supply fuel to both connected burner units.

7.5.5 Pressure Gauge

A pressure gauge is fitted to the valve block up stream (fuel tank side) of the main valve to show the operating pressure of the burner as well as indicating the presence of fuel pressure in the hose.

7.6 Fuel Tanks

Aluminium or stainless steel fuel tanks are used to store LPG under pressure for delivery to the burner system.

Two configurations of fuel tanks are available;

Master: Liquid supply and a regulated vapour supply for vapour pilot lights.

Slave : Liquid supply only.

Liquid outlets may be standard handwheel type valves or 90 degree quick shut off type valves. Liquid is withdrawn through an internal dip tube that extends to the bottom of the tank.

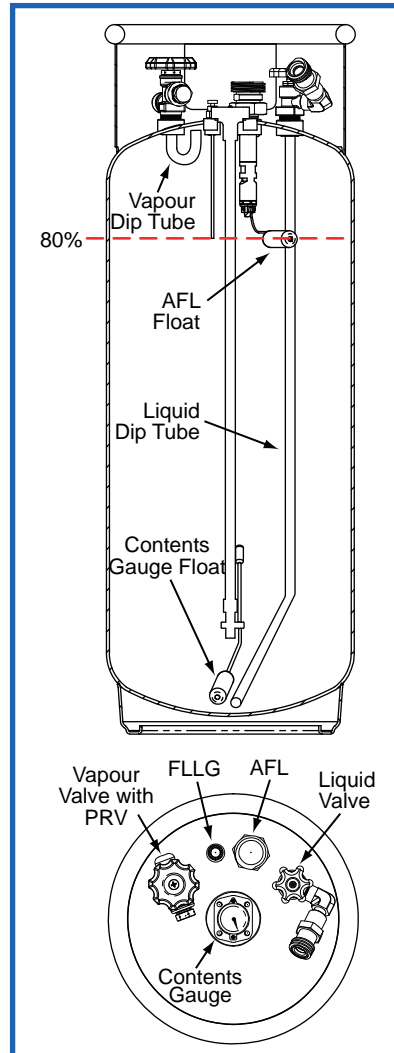

• Fuel Tank



7.4 Launch Restraints

Two types of launch restraint are recommended, the three ring quick release and the Bonanno quick release.



The choice of restraint to be used is up to the pilot however the webbing three ring release is not recommended for use on balloon above 210,000 cu.ft in launch wind speeds above 5 knots.

• Three ring release assembly

In all cases, the launch restraint must only be used during inflation and launch and must not be used for tethering operations.

Where a rope or webbing vee bridle is used with a three ring release, the release must be isolated with a knot such that it can not slide along the bridle.



• Rope vee bridle

All rope or webbing components in the release system must be protected from extended exposure to sunlight as their strength will degrade over time.

Basket launch restraint lugs may be fitted to double tee baskets at manufacture and provide a fixed point for attaching either a vee bridle or sling style release with a Bonanno release.



• Basket launch restraint lugs



7.5 Burner System

The Series 3 burner consists of either one, two, three or four single barrel natural draught, high-pressure, propane burners.

These are mounted on a tubular frame and are gimballed to allow the burners to swivel during use.

There is a friction control, which will allow movement when desired but should be adjusted so the burner will not tilt when unattended.

7.5.1 Main Burner

The main burner is operated by 90 degree action Worcester 44 ball valves, which are fitted to purpose made manifold blocks at the base of the burner cans.

Fuel enters a series of three vaporizing coils before exiting at the main jet ring through 6 jets and being ignited by a vapour pilot light.

7.5.2 Liquid Fire

The Liquid Fire is a secondary burner, fed from the same liquid propane supply as the main burner.

The liquid fire is operated by a smaller 90 degree ball valve which feeds liquid propane directly to a multi hole jet near the pilot light, bypassing the heat exchanger coil.

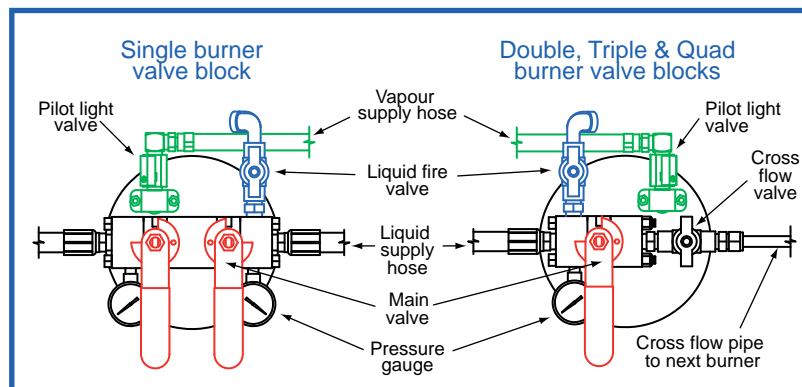

• Series 3 burner valve block layouts



Liquid fire has a lower noise level and the heat output is less than the main burner. It is intended primarily for over flight of animals and is only recommended for use in stable flight.

When operating Liquid Fire the valve should be opened slowly to ensure ignition of the fuel before it is opened fully. This secondary burner should only be used when there is a real need, such as close proximity to stock, as it will produce an amount of carbon powder which will discolour the balloon fabric.

7.5.3 Pilot Lights

Ignition of the main burner and liquid fire is achieved by use of a vapour pilot light. The pilot light is a separate system from the main burner and draws fuel from the vapour valve on a master tank through a regulator to reduce the line pressure to approximately 100kpa.

The pressure from the regulator may be varied to suit the pilot by adjusting the knob at the end of the regulator on the tank.

Clockwise adjustment of the regulator will increase the pressure. Care should be taken to not operate at very low pressure, as there may be a danger of accidentally extinguishing the pilot flame.

The pilot burner is a tube and cup arrangement in the bottom of the main burner and is fitted with a Peizo electric igniter for ease of ignition.

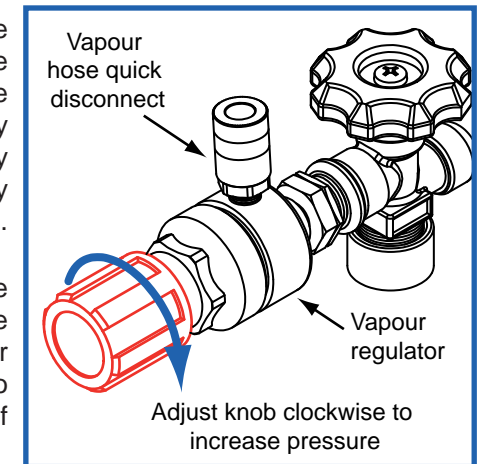

• Vapour regulator

On double burners, each pilot light is fitted with a separate vapour supply hose, so each burner system is separated into two redundant units. Triple and quad burners may have up to two pilot lights in series so there are only two vapour supply hoses.



7.10.5 Aircotec Piccolo Plus/ACT5000

The Aircotec Piccolo Plus is a digital altimeter and variometer.

Aircotec Piccolo Plus ACT5000 is the same as the Piccolo Plus, but has an infra red envelope temperature sensor as well as the standard features.

Mounting is by Velcro straps to the basket or uprights.

7.11 Radio Systems

No radio system is fitted as standard, however approved hand held VHF and/or UHF radios may be used from time to time as the flight requirements dictate.

7.12 Equipment Lists

The following lists of equipment set out the approved combinations of components. Each component is assigned a letter which can then be compared to the other components to show compatibility.

All fuel tank sizes can be used in all baskets provided the top rim of the fuel tank is below the top edge of the basket.

With regard to basket and envelope combinations, provided the load frame to envelope interface is accepted in 7.12.1, and the minimum burner requirement is fulfilled in 2.1, baskets of a lower gross certificated weight (GCW) than the envelope may be used provided the GCW for the envelope is lowered to that of the basket.

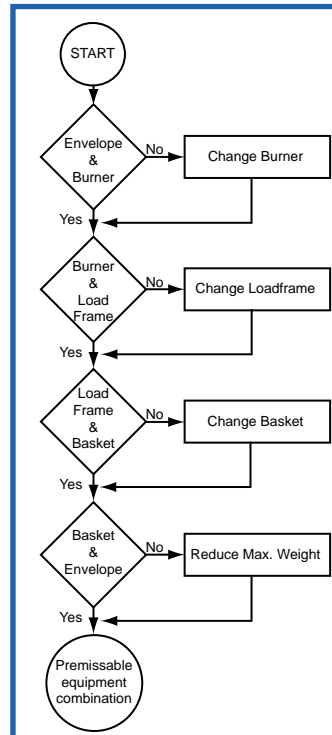

• Equipment selection



Vapour valves are hand wheel type valves and draw vapour from the top of the tank through a short U shaped dip tube.

All tank configurations will have a fixed liquid level gauge (FLLG or bleed valve), contents gauge and pressure relief valve. The pressure relief valve may be a separate unit or is incorporated into the rear of the vapour valve.

Automatic Fill limiters may be fitted and allow for safe and easy refuelling at service stations. Details for filling with AFL's are in Section 8 - Servicing.

7.6.1 Fuel Tank Capacity

Four sizes of fuel tanks are available. The model number of each refers to the absolute capacity (in litres) of the fuel tank.

The usable capacity is the amount of fuel that may be withdrawn from the tank.

The table below sets out the filled and usable capacity when the tank is correctly filled to the 80% level.

Table 6 - Fuel tank capacity

Model	Capacity (litres)	Usable Capacity
Worthington 47	38	37
Mytton 55	44	43
Kavanagh 55	44	43
Kavanagh 76	61	59.5
Kavanagh 82	66	64.6

7.6.2 Contents Gauge

The contents gauge indicates fuel capacity from approximately 30% to empty. The fixed liquid level gauge is the only indication of a full tank.

If a tank is not registering a fuel quantity between 30% and empty, and



is not registering as full at the FLLG then weighing is the only method to determine the remaining fuel in the tank.

7.7 Mini Vapour Tanks

5kg Worthington aluminium tanks may be used for a dedicated vapour supply to vapour pilot light systems. The tank will have a pressure regulator and either one or two connections for the vapour hoses from the burner.

The use of a separate vapour supply allows pressurisation of all fuel tanks with nitrogen or CO₂ in cold conditions or where high butane content in the fuel is causing low fuel pressure.

7.8 Fuel Manifolds

Approved fuel manifolds may be used to connect multiple fuel tanks so that burner fuel lines do not need to be disturbed in flight.

Two way manifolds will join two fuel tanks to one main burner hose while a three way manifold will join three tanks to one main burner hose.

When a manifold is to be used, all ends of the manifold must be connected to fuel tanks.

7.9 Fuel

Any commercially available LPG is suitable. This includes propane/butane mixtures commonly used to fuel automotive vehicles.

In all cases, the fuel pressure limitations must be met and should be confirmed on all flight tanks prior to launch.

Refer to the limitations section of this manual.

7.10 Instrumentation

Several types of instrument pack may be used. These are shown below.

If the chosen instrument pack does not have an envelope temperature sensor, a melting link warning device must be used.



7.10.1 Ball 655/M55

The Ball 655 and M55 balloon pack has an 0-20,000ft. digital altimeter, a two scale electric variometer and an envelope and ambient temperature indicator.

The Ball M55 balloon pack is a new model and replaces the 655 pack. It has updated electronics and stores elapsed flight time and peak envelope temperature.

Mounting is in a padded bag with Velcro ties for installation in the basket.

7.10.2 Ball 659

The Ball 659 balloon pack is the same as the 655 except there is no ambient or envelope temperature gauge fitted. This pack must be used with a separate ambient thermometer.

7.10.3 Flytec 4005/4010/3040/6005/6010

Flytec 4005/4010/6005/6010 instrument pack has a digital altimeter, variometer, ambient temperature sensor. The 3040 also has a remote envelope temperature sender.

Mounting is by Velcro straps to the basket or uprights.

7.10.4 Brauniger AV & IQ Classic/Competition

Brauniger AV-Classic & IQ Classic both feature a digital altimeter and variometer and ambient temperature indication.

Brauniger AV-Competition and IQ-Competition, both have the same features as the Classic, but also have an inbuilt barograph. An additional feature found on the Competition IQ GPS, is a socket for connection of a GPS, the data from which is stored alongside the barograph data. This gives a complete picture of each flight, showing time, altitude and position.

Mounting is by Velcro straps to the basket or uprights.



7.12.5 Fuel Tank List

Table 11 - Fuel tanks

Group	Model	Description
A	Worthington 47	Aluminium
B	Mytton 55L Kavanagh 55L Kavanagh 72L Kavanagh 76L Kavanagh 82L	Stainless Steel



The flow chart provides a simple system for confirming all main components are compatible.

Enter the chart at the top and follow the YES line where components are compatible based on information in 7.12 and the NO line where they are not.

Always refer to section 5.3, loading system.

7.12.1 Envelope list

Table 7 - Envelopes

Model	Burner	Basket	Load Frame	GCW (Kg)
B-77	B,C	A,B	A,B	760
B-105	C	B	A,B	1030
B-350	D,E	F,G	E	2800
B-400	E	F,G	E	3100
C-56	A,B,C	A	A,B	550
C-65	A,B,C	A	A,B	635
C-77	B,C	A,B	A,B	760
D-77	B,C	A,B	A,B	760
D-84	B,C	B	A,B	824
D-90	C	B	A,B	902
D-105	C	B	A,B	1030
E-120	C	B,C	B,C	1175
E-140	C	B,C	B,C	1300
E-160	C,D	C,D,E	B,C	1400
E-180	C,D	D,E	C,D	1450
E-210	C,D,E	D,E	D	1900
E-240	D,E	E,F	D,E	2000
E-260	D,E	E,F	D,E	2200
E-300	D,E	E,F	D,E	2500
EX-65	B,C	A,B	A,B	638
G-450	E	G	E	3700



7.12.2 Basket List

The nominal size of each basket is indicated by the numbers following the prefix. Example: The part number for a single tee basket 2.7 metres long by 1.5 metres wide is KST2715.

Table 8 - Baskets

Group	Model	Description	Load Frame	GCW (Kg)
A	KLW1010	Light weight, open	A,B	760
A	KLW1110	Light weight, open	A,B	
A	KLW1210	Light weight, open	A,B	
A	KOB1010	Standard, open	A,B	
A	KOB1110	Standard, open	A,B	
A	KOB1210	Standard, open	A,B	
B	KOB1410	Standard, open	A,B	1400
B	KOB1510	Standard, open	A,B	
B	KOB1610	Standard, open	A,B	
B	KOB1810	Standard, open	A,B	
C	KMT1812	Mini Tee	A,B	1400
C	KMT2012	Mini Tee	A,B	
C	KST1812	Single Tee	A,B	
C	KST2012	Single Tee	B,C	
C	KST2014	Single Tee	B,C	
C	KST2212	Single Tee	C	
C	KST2214	Single Tee	C	
D	KST2415	Single Tee	C	1800
D	KST2515	Single Tee	C	
E	KST2715	Single Tee	D	2200
E	KST2816	Single Tee	D	
E	K4DT2715	4 point Double Tee	D	
E	K4DT2815	4 point Double Tee	D	
E	K4DT2915	4 point Double Tee	D	
E	K4DT3215	4 point Double Tee	D	
F	K8DT3615	8 point Double Tee	E	2800
G	K8DT4015	8 point Double Tee	E	3700
	K8DT4315	8 point Double Tee	E	
	K8DT5015	8 point double tee	E	



7.12.3 Load Frame List

Table 9 - Load frames

Group	Model	Description	Burner
A	K4LF7661	4 Point 760 x 610	A,B,C
B	K4LF7676	4 Point 760 x 760	B,C
C	K4LF1010	4 Point 1000 x 1000	C,D
D	K4LF1210	4 Point 1200 x 1000	C,D,E
E	K8LF2010	8 Point 2000 x 1000	C,D,E

NOTE: The above loadframes may be fitted with a cross bar suitable for burners with the universal mount gimbal. The load frame part number will have the suffix "-CB" in such cases.

7.12.4 Burner List

Table 10 - Burners

Group	Model	Description
A	KBS1-1	Series 1, Single
	KBS1-2	Series 1, Double
B	KBS2-1	Series 2, Single
	KBS3-1	Series 3, Single
C	KBS2-2	Series 2, Double
	KBS3-2	Series 3, Double
D	KBS3-3	Series 3, Triple
E	KBS3-4	Series 3, Quad



4. After refuelling, the FLLG should be used to confirm the fuel level after filling to ensure the tank has not been overfilled or under filled.
5. A solid, continuing stream of liquid from the FLLG indicates the tank may be over full and the excess LPG should be removed in a safe location, preferably by burning.

NOTE: *Notwithstanding the advice given in this section, the reader is reminded it is the pilot's responsibility to ensure compliance with any laws governing the refuelling of LPG containers.*

8.4 Water Contamination

If water contamination is suspected, a couple of teaspoons of Methyl Alcohol, (Methylated Spirits), should be added to each tank. The simplest method is to pour the Methyl Alcohol into the filler hose before connecting to the tank. The procedure used to put this method into practice will vary with the type of fittings used.

This is more important for master tanks, which have a vapour outlet for the pilot burner. This action will prevent a build-up of ice at the pilot burner jet, and which could, in some cases cause total blockage of the jet.

8.5 Fuel Tank Pressurization

The burner has a normal operating pressure range of 350-1500Kpa, (50-218 PSI). Flying a hot air balloon with the fuel pressure below 450KPA (65PSI) requires care due to reduced burner power output.

In order to provide increased fuel pressure during cold weather or where fuel has a high Butane content, fuel tanks may be pressurized with nitrogen or CO₂.

WARNING: *Only Nitrogen and CO₂ are approved for pressurization. The use of other gasses may present a risk.*

The gas used to pressurize tanks must be from a regulated supply,



SECTION 8 – SERVICING

8.1 Servicing Introduction

This section contains information on recommended procedures for refuelling and storage of the fuel system.

8.2 Nature of Propane

Propane remains in liquid form only when contained under high pressure or at extremely low temperatures.

Propane droplets vapourize very quickly at room temperature and this causes an extreme cooling effect. Severe freeze burns can occur from contact with liquid propane which boils at -43° Celsius.

The following table may be used as a guide for vapour pressure of different LPG types at varying ambient temperatures.

NOTE: *These temperatures are not ambient air temperatures. The table below shows the temperature of the liquid contained in the tank.*

Table 12 - Fuel pressure vs temperature

Temp. 0°c	Pressure Kpa		
	Propane	Butane	50/50 mix
0	380	0	210
5	460	20	270
10	550	40	330
15	660	70	400
20	770	110	480
25	880	150	560
30	1010	190	650

Propane in its gaseous state is approximately 1.5 times heavier than air. Propane gas will therefore collect at the lowest unventilated point.



8.3 Refuelling

Although fuel tanks are normally filled at approved filling stations, it is common at balloon meets for the refuelling to be carried out by the pilot or crew. Therefore it is important to be familiar with refuelling procedures.

It is acceptable to refuel tanks in the basket, because the open wicker or drain holes in ply floor baskets provide adequate ventilation for gas to escape.

It is important to ensure drain holes are never blocked.

If the basket is being refuelled in a trailer, the trailer must have adequate ventilation to allow any gas to escape. Refuelling in enclosed trailers is not recommended.

There are two different procedures which may be used, depending on whether or not the tanks are fitted with automatic fill limiters (AFL).

8.3.1 Filling Tanks not fitted with Fill Limiters

1. Before refuelling, an inspection should be made to ensure there is no damage or wear to the fuel system which could be a safety hazard.
2. Ensure there are no ignition sources present. e.g. open flames, running engines, lit cigarettes, mobile phones, radios etc.
3. Wear suitable protective clothing, (long sleeve cotton shirt and leather gloves), and have a fire extinguisher on hand. Do not wear synthetic clothing unless it is made from Nomex.

WARNING: All tanks to be filled should be electrically earthed during refuelling, or during venting of vapour for any reason.

4. Connect the end of the filler hose to the liquid outlet, (1 ¼" Acme thread safety connector), and open the liquid outlet valve, as well as the fixed liquid level gauge.
5. If a pump is being used, the fixed liquid level gauge should only



be turned on a little. If the filling method is by decanting without a pump, there needs to be a higher flow from the fixed liquid level gauge so the pressure in the tank to be filled remains below that of the supply tank.

6. The fixed liquid level gauge has a dip tube inside the tank, the bottom of which is at the level of 80% of the total volume of the tank. When this level is reached during filling, liquid will spurt out, giving a visual indication that the tank is full. The fuel flow, tank outlet valve, and the fixed liquid level indicator valve should be immediately shut off.
7. Never allow a fuel tank to be filled above its normal liquid level as indicated by the fixed liquid level gauge. This could allow expansion from an ambient temperature rise to fill the tank completely and cause the unexpected release of propane from the pressure relief valve.
8. Pressure between the tank outlet valve and the 1¼" self sealing coupling on the tank should be released immediately after the filler hose is removed from the tank.

8.3.2 Filling Tanks fitted with Fill Limiters (AFL)

1. Follow the steps set down in parts a, b, c and d of the preceding instructions.
2. Tanks with a fill limiter fitted must be pump filled for the fill limiter to operate. The fill limiter has a 1¾" Acme thread, which is the same as the bowser end of an automotive pump at a service station.
3. The pump hose is screwed directly onto the fill limiter. The time spent refuelling is greatly diminished when filling through this fitting. When the fuel level reaches 80%, the flow is automatically shut off and the pump hose may be immediately unscrewed and switched to the next tank.

NOTE: The bleed screw on the fixed liquid level indicator does not need to be opened when filling through an AFL.



THIS PAGE INTENTIONALLY BLANK



capable of providing a pressure of between 0-1500KPA, (0-218PSI) to the fuel tank.

The gas used to pressurize tanks is added to the tank through the liquid feed valve on the tank until the desired pressure level is reached. It is recommended that pressurization is only carried out just prior to flight.

Sufficient master tanks must remain free of Nitrogen or CO₂ and be easily identifiable for vapour pilot light operation.

NOTE: *The maximum fuel tank pressure must not exceed 1500KPA, (218PSI).*

NOTE: *It is recommended that any fuel tank which has been pressurized with nitrogen is labelled as such, and that extra care is taken with the use and storage of the tank. Alternately, vapour regulators should be removed and the vapour valve plugged.*

CAUTION: *If the tank is to be stored in a pressurized state, the maximum fuel tank pressure must not exceed 700KPA, (100PSI).*

WARNING: *A fuel tank that has been pressurized with nitrogen must not be used for vapour supply to vapour pilot lights. Contamination of the vapour space in the fuel tank may cause pilot light failure.*

8.5.1 Storage of Pressurized Tanks

When fuel tanks, which have been pressurized with Nitrogen or CO₂ are warmed, the fuel pressure will rise more rapidly than that of an unpressurized tank.

Pressurized fuel tanks requiring storage must have the pressure reduced to an acceptable level to ensure that the maximum safe working tank pressure is never exceeded.

Where possible, the pressure must be reduced to 700KPA (100PSI) by opening the fixed liquid level gauge, (bleed valve), and allowing vapour



to escape until the tank pressure is reduced to a suitable level. Care must be taken to ensure this is done in a suitable and safe location. This venting procedure may take ten minutes or so to reduce the pressure back to normal tank pressure. When using this procedure, the same precautions must be taken as when refuelling the tanks.

NOTE: *Hot ambient conditions may prevent a reduction in pressure to below 700KPA, in such cases, the venting procedure should be carried out for not less than the recommended 10 minutes.*

8.5.2 Refuelling Pressurized Fuel Tanks

Before refuelling a tank which has been pressurized, the nitrogen or CO₂ content must be expelled by opening the fixed liquid level gauge and bleeding off vapour for several minutes. This will reduce the vapour pressure of the tank to normal and alleviate any problems which may be caused by high pressure during the filling process. Care must be taken to ensure this is done in a suitable safe location.

NOTE: *A pressurized tank may cause problems with pump filling and will cause slow or no flow when decanting.*

8.5.3 Returning to use as a Master Tank

If a previously pressurized tank is to be returned to use as a master tank with a vapour supply for pilot burners, it must be vented as described above then emptied and refilled with the fixed liquid level gauge (bleed valve) open during filling.

Extra care should be taken when this tank is first used to ensure the pilot burner operates correctly and provides a stable flame.

It is important that the use of high pressure nitrogen or CO₂ is carried out with reference to the safety, handling and storage guidelines in place for these cylinders. Local and National regulations concerning the use of these cylinders must be complied with. The supplier of the nitrogen or CO₂ cylinders will be able to supply the necessary information.



SECTION 9 - SUPPLEMENTS

The installation and operation of optional equipment not included in the body of the Flight Manual is covered in this supplement Section.

Where applicable, operation of the balloon shall be in accordance with the supplement and the Flight Manual.

Information in the relevant supplement takes precedence over that in the Flight Manual.

Applicable supplements are listed in Section 0-4 of this Flight Manual.